

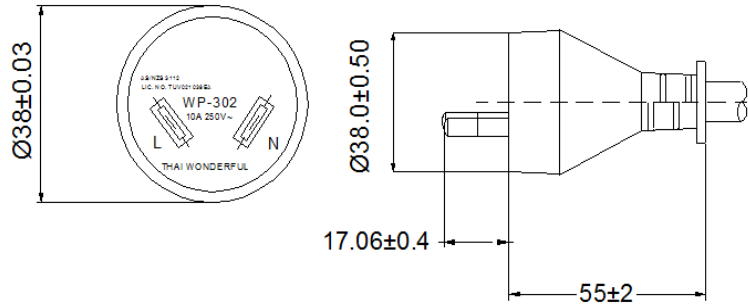

PLUG WP-302



STANDARD

AS/NZS 3112:2011+A1+A2+A3, AS/NZS 3100:2009+A1+A2+A3+A4	
Safety Mark	WP-302 TUV021149EA
Logo of safety mark	AS/NZS 3112 KIC. NO. TUV021039EA
Rate Current & Voltage Mark	7.5A 250V , 10A 250V
Attached wire cord	H03VV-F 2G 0.75SQMM H05VV-F 2G 0.75SQMM , 1.00SQMM , 1.50SQMM H05V2V2-F 2G 0.75SQMM , 1.00SQMM , 1.50SQMM

ELECTRICAL CHARACTERISTICS

<b>Resistance to Heat</b> 90±2°C , 6 HR	N/A
<b>TEMPERATURE RISING TEST</b> 45K(Max) (APPLIED 8.3A for 7.5A) (APPLIED 11A for 10A)	N/A
<b>Insulation Resistance</b> 100 MEFA Ohm / 500V DC, 1 Min	N/A
<b>WATER ABSORPTION TEST</b> NO SWELL, CHANGE (20°C , 48 HRS IN WATER)	N/A

PHYSICAL CHARACTERISTICS

Nominal Cable Diameter (mm)	4.38
Cable Cold Bend	-20±1°C x 4 Hrs
Minimum Bend Radius	15 times O.D.
Temperature Rating (°C)	20°C to 75°C
Temperature Voltage (V)	300

Packing : CARTON